

Use of nutritional supplements among south Italian students of Physical Training and Sport University

Filomena Mazzeo¹, Maria Letizia Motti¹, Giovanni Messina², Vincenzo Monda², Antonio Ascione¹, Domenico Tafuri¹, Filomena Palmieri², Antonietta Messina² and Marcellino Monda²

¹Department of Motor Sciences, University of Naples "Parthenope", Naples,

²Department of Experimental Medicine, Section of Human Physiology and Clinical Dietetic Service, Second University of Naples, Via Costantinopoli 16, 80138 Naples, Italy

ABSTRACT

It is generally known that talent and hard training are the main factors contributing to the success of an athlete; nevertheless athletes make use of various substances in an attempt to improve their performance. The aim of this study is: 1) the evaluation of diet supplements used by the students attending courses at the faculty of Motor Sciences in a southern Italian University. 2) the evaluation of the precise knowledge about nutritional supplements and risks related to their utilization. An anonymous questionnaire was distributed to 562 students attending the last year of the university course. This questionnaire focused on information regarding demographic characteristics, sporting activities and the use of nutritional supplements (frequency, types of substances and suppliers). A significant percentage (28.6%) of students admitted using nutritional supplements (absolute values: elite-n = 84; non-elite-n = 76). Among the 160 athletes using nutritional supplements: 34% practised bodybuilding and 32% football; 40% used minerals, 36.3% vitamins and 23.7% proteins; 20.1% took nutritional supplements regularly (>5 times per week), 35.3% occasionally (2-4 times per week), 44.6% seldom (<2 times per week); 45% bought supplements from a pharmacy and 21.9% from a sports coach; 41% of the athletes used nutritional agents at the suggestion of a sport coach trainer while only 19% and 6% on recommendation of a medical or nutritional consultant respectively. No adverse drug reactions have been reported. Among young people, and

particularly sports students, it is important to provide accurate information on the correct use of supplements and their potential damage.

KEYWORDS: sport, nutritional supplements, university

INTRODUCTION

Nutrition has been perceived as an essential component in physical performance since the beginning of sporting competition. Progress in the last few decades in the understanding of the human metabolism and of physical exercise physiology has made clear that a variation in nutritional intake may increase sports performance [1] positively. This knowledge has given rise to an explosion of products specifically designed for each type of physical activity. These substances are more and more used by athletes not only in competitive sports, but also in fitness and recreational sports [2].

Nutritional supplements can be grouped into dietary supplements, ergogenic aids and food for sport. Their use among athletes is very popular: most studies reported that over half of the athletes use supplements [3, 4]. Some studies reported that 88% of the athletes use one or more nutritional supplements [5].

A wide range of different types and brands of products for nutritional supplementation is nowadays widespread and generally accepted by the athletes [1].

The trend to enhance performance by using drugs is particularly alarming among adolescents [6, 7] and even pre-adolescents [8].

In order to become the strongest and fastest in their own field, many athletes consume potentially harmful or even banned nutritional supplements [9].

Officially, in 1996 in the United States about 6.5 billion US dollars were spent in general nutritional supplement purchase, reaching in 2002 18 billion US dollars, with sports nutritional products covering one-third of the sales [9].

In 1998 worldwide consumption of creatine was 2.7 million kilograms [10], and the sales of hydroxy-methyl-butyrate (HMB) reached 50-60 million US dollars, despite no evident proof of its efficacy in increasing muscle mass or strength [11].

This data supports the ergogenic potential of sports drinks and creatine, although most supplements have not been shown *via* clinical trial to enhance sports performance [12, 13, 14].

The main purpose of this study is:

- 1) the evaluation of diet supplements used by the students attending courses at the faculty of Motor Sciences in a southern Italian University
- 2) the evaluation of the precise knowledge about nutritional supplements and risks related to their utilization.

METHODS

562 students (aged between 18 and 30 years old, 363 males and 199 females), attending the last year at the Physical Education and Sport Faculty of the University of Naples "Parthenope". The data

was collected during the fall semester of the 2010/2011 academic year. The participants completed a self-report questionnaire. The questionnaire, without any identifying information, remained anonymous, so that athletes would answer freely.

We expect that the use of self-reported questionnaires might be suited to our purpose because the respondents, believing that the use of nutritional supplements is not prohibited, would not be reluctant to declare its use.

Queries included demographic data, type of sports activities, type of nutritional supplements and consumption frequency, and lastly information on the method of purchase.

RESULTS

562 questionnaires were distributed and all were returned; we analyzed only the 160 questionnaires in which the respondents admitted to the use of nutritional supplements. Two questionnaires were excluded because of missing data.

In our target group, 160 athletes declared that they used nutritional supplements (28.6%): 84 elite athletes and 76 non elite athletes. We define an elite athlete as an athlete who has participated or has been qualified to compete in a national or international competition. We found no significant differences in the supplements use by gender.

The most frequent reasons for using nutritional supplements are an easy victory in sports as well as an increased endurance and performance (40.5%), followed by increased strength (15.5%), tear injuries (20.3%) and other reasons (23.7%) (Figure 1). This finding is in accordance with the literature data [9, 15].

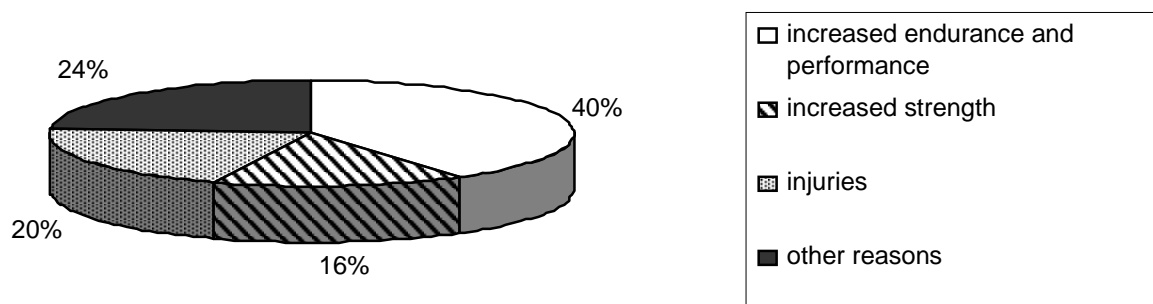

Figure 1. Reasons of the use of nutritional supplements.

Regarding the frequency of use and the source of information of nutritional supplements, the results obtained have been: 20.1% of the athletes surveyed used a nutritional supplement regularly (>5 times per week), 35.3% occasionally (2-4 times per week) and 44.6% seldom (<2 times per week) (Table 1). In addition, 66 athletes (41%) used nutritional agents on the suggestion of an athletic trainer while only 19% and 6% on the recommendation of a medical or nutritional counselor, respectively.

The sports undertaken by athletes using nutritional supplements: 34% do body building; this is a sport where appearance is significant, so the athletes often resort to the use of substances that enhance their physical appearance; another 32% play football; this is a fairly high level and is

justified by the fact that football is a sport of endurance and is among the most popular sports in Italy (Figure 2).

Among 160 athletes who admitted the use of nutritional supplements, 40% declared the use of minerals, 36.3% vitamins and 23.7% proteins (Table 2). These athletes, however, reported following an adequate nutritional program.

Data indicates that among 160 nutritional supplement users, 72 bought supplements from a pharmacy (45%) and 35 from athletic trainers (21.9%) (Table 3). In such cases it is very important to buy these supplements from authorized suppliers (such as pharmacies) and not on the internet or from people who buy products of unknown origin [1, 9].

Table 1. Frequency and percentage of use of dietary supplements.

Use of dietary supplements	Frequency	Percentage
Regularly (>5 times per week)	32	20.0
Occasionally (2-4 times per week)	57	35.6
Seldom (<2 times per week)	71	44.6
	160	100.0

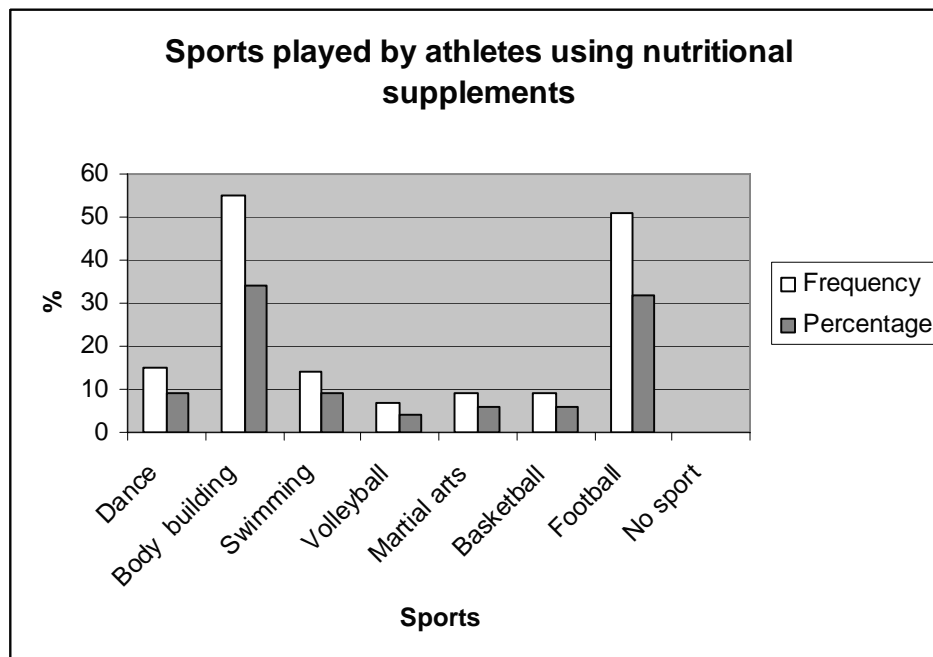

Figure 2. Sports played by athletes using nutritional supplements.

Table 2. Type of nutritional supplements used by athletes.

Supplements	Frequency	Percentage
Minerals	64	40.0
Vitamins	58	36.3
Proteins	38	23.7
	160	100.0

Table 3. Nutritional supplements' modality of purchase.

Modality of purchase	Frequency	Percentage
Supermarket	20	12.5
Gym	20	12.5
Athletic trainer	35	21.9
Internet	5	3.1
Pharmacy	72	45.0
Para pharmacy	4	2.5
Herbalist's shop	4	2.5
	160	100.0

DISCUSSION

This analysis provides a representation of nutritional supplement usage among young Physical Education and Sports Faculty students.

To use supplements safely, it is important to consult doctors or nutritionists who know the quantity and frequency of supplements that can be used without harm to health [1, 12]. Instead, because young students do not consider the nutritional supplements "real" doping, they believe that in order to buy these substances it is sufficient to follow the advice of a trainer, without previously consulting a doctor or a nutritionist (41% of the users of nutritional agents in our group).

In literature there are many examples of nutritional supplements used in a potentially dangerous way. For example, chromium nutritional supplements used at low concentrations are not toxic but high concentrations are likely to produce genotoxic DNA lesions in the cell nucleus [16] and, taken in the same vein together with selenium, it can be significantly toxic, if ingested in large amounts [17].

Carnitine has become a popular ingredient in dietary supplements; nevertheless the safety of

prolonged usage, for an intake above 2 g/day has not yet been established [18]. Finally, the ingestion of L-tryptophan (LT)-containing products has been associated with a disorder known as eosinophilia-myalgia syndrome (EMS) [19, 20].

It is very alarming that 28.6% of our sample dietary supplements users, who in the course of their studies, should have obtained awareness of the dangers of irresponsible use of nutritional supplements, are still convinced that, in some cases, nutritional supplements can be harmless and not hazardous to their health. This happens because in sporting clubs it is common to consider supplements absolutely harmless [10]. For this reason the spread of information on the use of supplements should be very well publicized and should involve various areas and sports facilities. The consensus is that the use of nutritional supplements does not represent a serious public health problem [21]. Indeed, many athletes consume nutritional supplements, sports drinks, multivitamins or similar products for their perceived physiological benefits but they are not aware of any potential risks [22].

The use of nutritional supplements is the cause of "inadvertent" doping. In fact an important problem

is that sometimes nutritional supplements are contaminated by substances that are real doping agents [23]. There is evidence that some of the apparently legitimate dietary supplements contain ingredients not declared on the label, which are prohibited by the doping regulations of the International Olympic Committee and the World Anti-Doping Agency (WADA) such as pro-hormones [24] (steroid-related compounds such as androstenedione, DHEA, 19-norandrostenedione) and stimulants such as ephedrine or related substances [25, 26, 27]. This contamination may cause potential health problems, for example, the ingestion of products containing ephedra is often the source of cardiovascular adverse effects causing even sudden death [28].

Another important consequence of the unintentional ingestion of prohibited substances is that elite athletes risk breaking anti-doping regulations [29]. The involuntary ingestion of prohibited substances is not an acceptable excuse in sports regulations and athletes tested positive are liable to severe penalties. Anyway, the athletes need to be made aware of the problems that can derive from supplement consumption. The athletes should ask the anti-doping agencies of their countries about the specific risks of supplement use and about any initiatives to reduce these risks [30].

CONCLUSION

We can conclude that sports practitioners have particular responsibilities in addressing a program to promote a diet adequate to support the various sports and the athletes. In any case, they need to be aware of the problems that can follow the use of supplements. The need to educate the future athletic trainers about several common nutritional supplements, their mechanism of action, potential benefit and possible adverse reaction should be clearly understood. With this knowledge the athletic trainers can intelligently advise their athletes who are already using nutritional supplements. The use of supplements, especially among physical education and sports students, should be indicated in the case of special nutritional deficiencies or in the case of special sports needs and not just to improve athletic performance. Intervention and prevention efforts should be particularly targeted to adolescents [1].

In addition, many supplement products contain substances that are prohibited in sport or that have been associated with significant morbidity and mortality. Essential information about ergogenic substances may help to establish a sound relationship with athletes using these nutritional supplements. Greater information about supplements is associated with lesser use; hence education about supplements can be a deterrent to their improper use [22].

Widespread use of nutritional supplements, combined with an absence of evidence of their efficacy and a concern for the possibility of “inadvertent” doping, points to the need for information and dissemination activities along with educational initiatives and programs on the subject at all levels [27]. Market regulation is complicated by the increasing popularity of Internet sales.

The use of dietary supplements is recommended especially in cases of nutritional deficiencies as there is no scientific evidence that the use of vitamins and minerals improves athletics performances [1, 12].

Indeed, the use of supplements, including those aimed at sports people, must be discouraged; in most cases it serves no purpose [1, 2].

A good training program, on-time natural recovery of the organism of athletes, and the adoption of sound eating habits are the only factors that can improve athletic ability naturally. Therefore, the use of supplements in sports needs to be led by doctors and nutritionists. Knowledge of nutritional supplements and recommended daily allowances are unfortunately still generally poor.

PERSPECTIVES

The athletes using drugs or nutritional supplements practice mainly sport where appearance is a significant aspect as in body building.

The use of nutritional supplements is not considered hazardous to health. Many of these students consume nutritional supplements, sports drinks, multivitamins or similar products for their perceived physiological benefits but they are not aware of any potential risks.

There is evidence that some of the apparently legitimate dietary supplements contain ingredients that are not declared on the label, which are prohibited by the doping regulations of the International Olympic Committee and the World Anti-Doping Agency.

REFERENCES

1. Molinero, O. and Márquez, S. 2009, *Nutr. Hosp.*, 24, 128-134.
2. Slater, G., Tan, B. and The, K. C. 2003, *Int. J. Sport Nutr. Exerc. Metab.*, 13, 320-332.
3. Sobal, J. and Marquart, L. F. 1994, *Int. J. Sport Nutr.*, 4, 320-334.
4. Krumbach, C. J., Ellis, D. R. and Driskell, J. A. 1999, *Int. J. Sport Nutr.*, 9, 416-225.
5. Burns, R. D., Schiller, M. R., Merrick, M. A. and Wolf, K. N. 2004, *J. Am. Diet Assoc.*, 104, 246-49.
6. Koch, J. J. 2002, *Pediat. Rev.*, 23, 310-317.
7. Yesalis, M. P. H. and Bahrke, M. S. 2000, *Ballieres Best Pract. Res. Clin. Endocrinol. Metab.*, 14, 25-35.
8. Laure, P. and Binsinger, C. 2007, *Br. J. Sports Med.*, 41, 660-663.
9. Tian, H., Ong, W. S. and Tan, C. L. 2009, *Singapore Med. J.*, 50, 165-172.
10. Bird, S. P. 2003, *J. Sport Science Med.*, 2, 123-132.
11. Slater, G. J. and Jenkins, D. 2000, *Sports Med.*, 30, 105-116.
12. Burke, L. M. and Read, R. S. 1993, *Sports Med.*, 15, 43-56.
13. Williams, M. H. 1995, *J. Sports Sci.*, 13, 63-74.
14. Maughan, R. J., Greenhaff, P. L. and Hespel, P. 2011, *J. Sports Sci.*, 29, 57-66.
15. Froiland, K., Koszewski, W., Hingst, J. and Kopecky, L. 2004, *Int. J. Sport Nutr. Exerc. Metab.*, 14, 104-120.
16. Levina, A. and Lay, P. A. 2008, *Chem. Res. Toxicol.*, 21, 563-571.
17. Aldosary, B. M., Sutter, M. E., Schwartz, M. and Morgan, B. W. 2012, *Cin. Toxicol.*, 50, 57-64.
18. Hathcock, J. N. and Shao, A. 2006, *Regul. Toxicol. Pharmacol.*, 46, 23-28.
19. Roufs, J. B. 1992, *J. Am. Diet. Assoc.*, 92, 844-850.
20. Hill, R. H. Jr., Caudill, S. P., Philen, R. M., Bailey, S. L., Flanders, W. D., Driskell, W. J., Kamb, M. L., Needham, L. L. and Sampson, E. J. 1993, *Arch. Environ. Contam. Toxicol.*, 25, 134-142.
21. Striegel, H., Simon, P., Wurster, C., Niess, A. M. and Ulrich, R. 2006, *Int. J. Sport Med.*, 27, 236-241.
22. O'Dea, J. A. 2003, *Health Education Res.*, 18, 98-107.
23. Geyer, H., Parr, M. K., Mareck, U., Reinhart, U., Schrader, Y. and Schänzer, W. 2004, *Int. J. Sports Med.*, 25, 124-129.
24. Kamber, M., Baume, N., Saugy, M. and Rivier, L. 2001, *Int. J. Sport. Nutr. Exerc. Metab.*, 11, 258-263.
25. Maughan, R. J. 2005, *J. Sports Sci.*, 23, 883-889.
26. Pipe, A. and Ayotte, C. 2002, *Clin. J. Sport Med.*, 12, 245-249.
27. Geyer, H., Parr, M. K., Koehler, K., Mareck, U., Schänzer, W. and Thevis, M. 2008, *J. Mass Spectrom.*, 43, 892-902.
28. Dhar, R., Stout, C. W., Link, M. S., Homoud, M. K., Weinstock, J. and Estes, N. A. 2005, *Mayo Clin. Proc.*, 80, 1307-1315.
29. Gurley, B. J., Wang, P. and Gardner, S. F. 1998, *J. Pharm. Sci.*, 87, 1547-1553.
30. Ambühl, P. M. 2011, *Int. J. Vitam. Nutr. Res.*, 8, 162-172.